

# Modern Maths

## Actual CAT Problems 1999-2005

---

### CAT 1999

- Ten points are marked on a straight-line and 11 points are marked on another straight-line. How many triangles can be constructed with vertices from among the above points?  
a. 495                      b. 550                      c. 1045                      d. 2475
- For a scholarship, at the most  $n$  candidates out of  $2n + 1$  can be selected. If the number of different ways of selection of at least one candidate is 63, the maximum number of candidates that can be selected for the scholarship is  
a. 3                              b. 4                              c. 6                              d. 5
- In a survey of political preferences, 78% of those asked were in favour of at least one of the proposals: I, II and III. 50% of those asked favoured proposal I, 30% favoured proposal II and 20% favoured proposal III. If 5% of those asked favoured all three of the proposals, what percentage of those asked favoured more than one of the three proposals?  
a. 10                              b. 12                              c. 17                              d. 22
- Three labelled boxes containing red and white cricket balls are all mislabelled. It is known that one of the boxes contains only white balls and another one contains only red balls. The third contains a mixture of red and white balls. You are required to correctly label the boxes with the labels red, white and red and white by picking a sample of one ball from only one box. What is the label on the box you should sample?  
a. white  
b. red  
c. red and white  
d. Not possible to determine from a sample of one ball

**Directions for questions 5 to 8:** Answer the questions based on the following information.  
 In each of the following questions, a pair of graphs  $F(x)$  and  $F_1(x)$  is given. These are composed of straight-line segments, shown as solid lines, in the domain  $x \in (-2, 2)$ .

**Choose the answer as**

- a. if  $F_1(x) = -F(x)$
- b. if  $F_1(x) = F(-x)$
- c. if  $F_1(x) = -F(-x)$
- d. if none of the above is true

5.

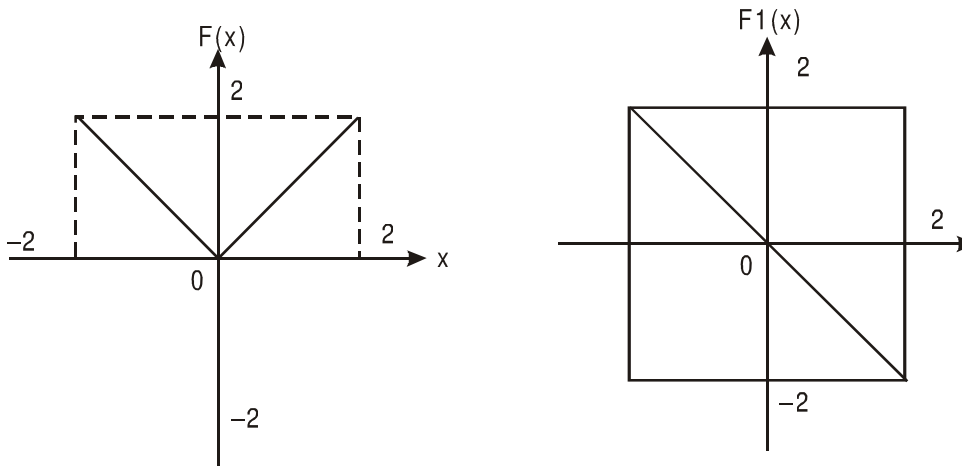

6.

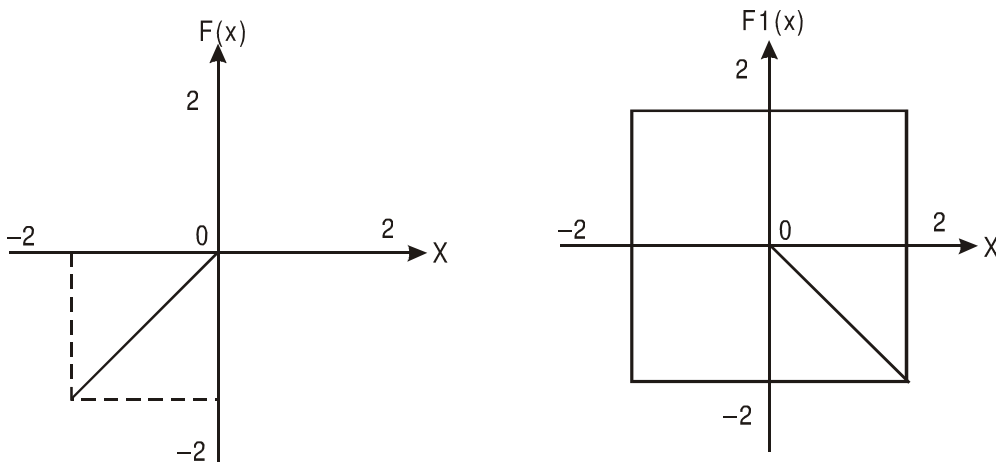

7.

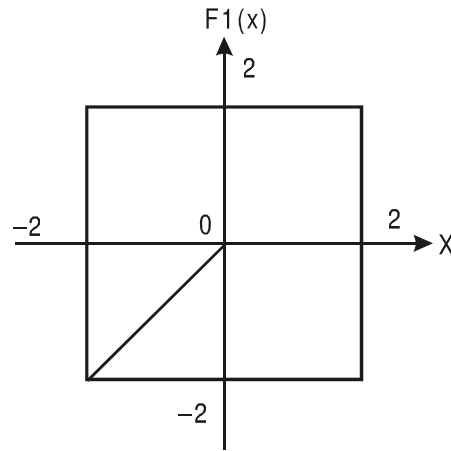
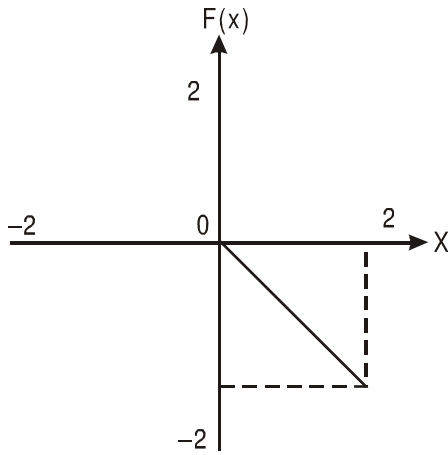

8.

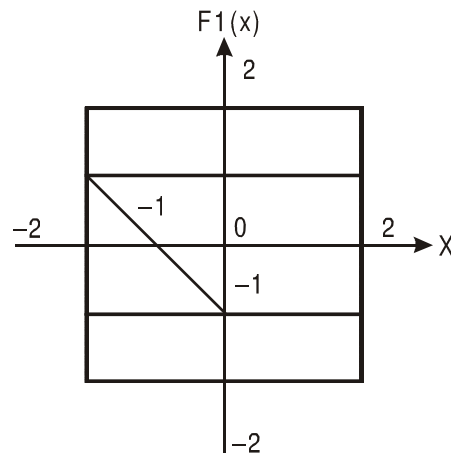
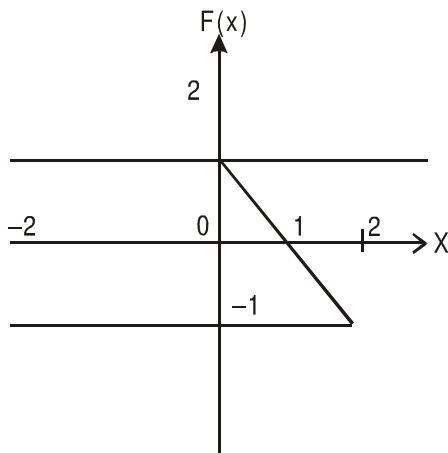

**Directions for questions 9 to 11:** Answer the questions based on the following information.

Let  $x$  and  $y$  be real numbers and let

$$f(x, y) = |x + y|, F(f(x, y)) = -f(x, y) \text{ and } G(f(x, y)) = -F(f(x, y))$$

9. Which of the following statements is true?
- $F(f(x, y)) \cdot G(f(x, y)) = -F(f(x, y)) \cdot G(f(x, y))$
  - $F(f(x, y)) \cdot G(f(x, y)) > -F(f(x, y)) \cdot G(f(x, y))$
  - $F(f(x, y)) \cdot G(f(x, y)) \neq G(f(x, y)) \cdot F(f(x, y))$
  - $F(f(x, y)) + G(f(x, y)) + f(x, y) = f(-x, -y)$

10. What is the value of  $f(G(f(1, 0)), f(F(f(1, 2)), G(f(1, 2))))$ ?  
 a. 3                                      b. 2                                      c. 1                                      d. 0
11. Which of the following expressions yields  $x^2$  as its result?  
 a.  $F(f(x, -x)) \cdot G(f(x, -x))$                                       b.  $F(f(x, x)) \cdot G(f(x, x)) \cdot 4$   
 c.  $-F(f(x, x)) \cdot G(f(x, x)) \div \log_2 16$                                       d.  $f(x, x) \cdot f(x, x)$

### CAT 2000

12. One red flag, three white flags and two blue flags are arranged in a line such that:  
 I. No two adjacent flags are of the same colour  
 II. The flags at the two ends of the line are of different colours
- In how many different ways can the flags be arranged?  
 a. 6                                      b. 4                                      c. 10                                      d. 2

**Directions for questions 13 and 14:** Answer the questions based on the following information.

A, B and C are three numbers. Let  
 $@(A, B)$  = Average of A and B,  
 $/ (A, B)$  = Product of A and B, and  
 $\times (A, B)$  = The result of dividing A by B.

13. The sum of A and B is given by  
 a.  $/ (@ (A, B), 2)$                                       b.  $\times (@ (A, B), 2)$   
 c.  $@ (/ A, B), 2)$                                       d.  $@ (\times (A, B), 2)$
14. Average of A, B and C is given by  
 a.  $@ (/ (@ (/ (B, A), 2), C), 3)$                                       b.  $\times (@ (/ (@ (B, A), 3), C), 2)$   
 c.  $/ (\times (\times (@ (B, A), 2), C), 3)$                                       d.  $/ (\times (@ (/ (@ (B, A), 2), C), 3), 2)$

**Directions for questions 15 and 16:** Answer the the questions based on the following information.  
 For real numbers x and y, let

$$f(x, y) = \begin{cases} \text{Positive square root of } (x + y), & \text{if } (x + y)^{0.5} \text{ is real} \\ (x + y)^2, & \text{otherwise} \end{cases}$$

$$g(x, y) = \begin{cases} (x + y)^2, & \text{if } (x + y)^{0.5} \text{ is real} \\ -(x + y), & \text{otherwise} \end{cases}$$

15. Which of the following expressions yields a positive value for every pair of non-zero real numbers (x, y)?  
 a.  $f(x, y) - g(x, y)$                                       b.  $f(x, y) - (g(x, y))^2$   
 c.  $g(x, y) - (f(x, y))^2$                                       d.  $f(x, y) + g(x, y)$

- 16.. Under which of the following conditions is  $f(x, y)$  necessarily greater than  $g(x, y)$ ?
- a. Both  $x$  and  $y$  are less than  $-1$                       b. Both  $x$  and  $y$  are positive  
c. Both  $x$  and  $y$  are negative                              d.  $y > x$

**Directions for questions 17 to 19:** Answer the questions based on the following information.

For three distinct real numbers  $x, y$  and  $z$ , let

$$f(x, y, z) = \text{Min}(\text{Max}(x, y), \text{Max}(y, z), \text{Max}(z, x))$$

$$g(x, y, z) = \text{Max}(\text{Min}(x, y), \text{Min}(y, z), \text{Min}(z, x))$$

$$h(x, y, z) = \text{Max}(\text{Max}(x, y), \text{Max}(y, z), \text{Max}(z, x))$$

$$j(x, y, z) = \text{Min}(\text{Min}(x, y), \text{Min}(y, z), \text{Min}(z, x))$$

$$m(x, y, z) = \text{Max}(x, y, z)$$

$$n(x, y, z) = \text{Min}(x, y, z)$$

17. Which of the following is necessarily greater than 1?
- a.  $[h(x, y, z) - f(x, y, z)] / j(x, y, z)$                       b.  $j(x, y, z) / h(x, y, z)$   
c.  $f(x, y, z) / g(x, y, z)$                                       d.  $[f(x, y, z) + h(x, y, z) - g(x, y, z)] / j(x, y, z)$
- 18.. Which of the following expressions is necessarily equal to 1?
- a.  $[f(x, y, z) - m(x, y, z)] / [g(x, y, z) - h(x, y, z)]$   
b.  $[m(x, y, z) - f(x, y, z)] / [g(x, y, z) - n(x, y, z)]$   
c.  $[j(x, y, z) - g(x, y, z)] / h(x, y, z)$   
d.  $[f(x, y, z) - h(x, y, z)] / f(x, y, z)$
- 19.. Which of the following expressions is indeterminate?
- a.  $[f(x, y, z) - h(x, y, z)] / [g(x, y, z) - j(x, y, z)]$   
b.  $[f(x, y, z) + h(x, y, z) + g(x, y, z) + j(x, y, z)] / [j(x, y, z) + h(x, y, z) - m(x, y, z) - n(x, y, z)]$   
c.  $[g(x, y, z) - j(x, y, z)] / [f(x, y, z) - h(x, y, z)]$   
d.  $[h(x, y, z) - f(x, y, z)] / [n(x, y, z) - g(x, y, z)]$

**Directions for questions 20 to 22:** Given below are three graphs made up of straight line segments shown as thick lines. In each case choose the answer as

- a. if  $f(x) = 3 f(-x)$
- b. if  $f(x) = -f(-x)$
- c. if  $f(x) = f(-x)$
- d. if  $3f(x) = 6 f(-x)$ , for  $x \geq 0$

20.

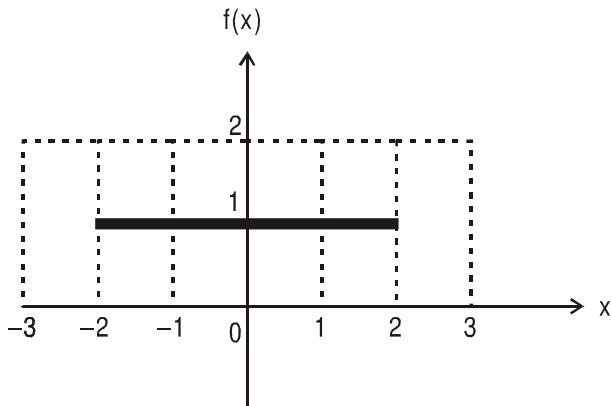

21.

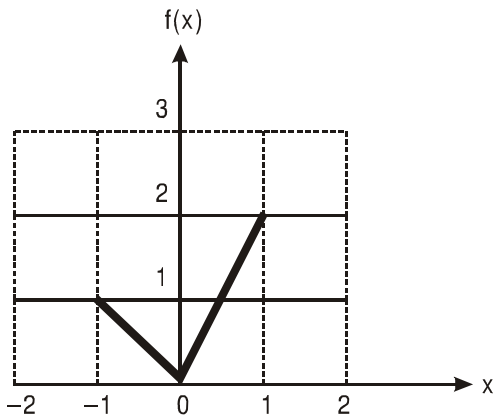

22.

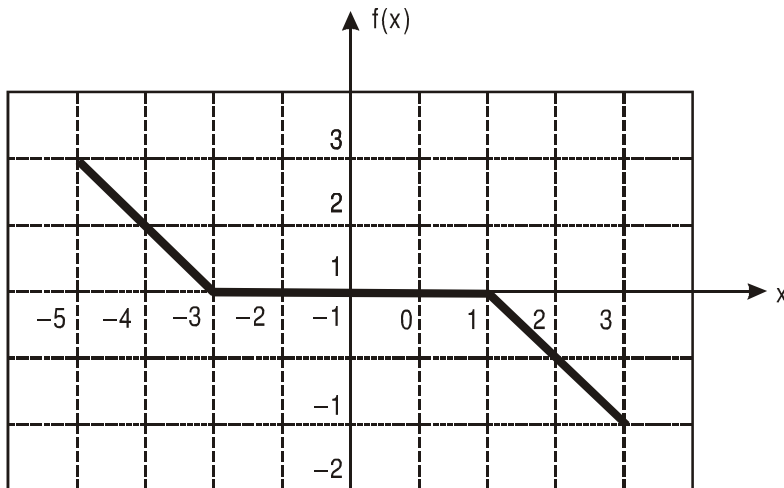

**Directions for questions 23 and 24:** Answer the questions based on the following information.

For a real number  $x$ , let

$$f(x) = \begin{cases} \frac{1}{1+x}, & \text{if } x \text{ is non-negative} \\ 1+x, & \text{if } x \text{ is negative} \end{cases}$$

$$f^n(x) = f(f^{n-1}(x)), \quad n = 2, 3, \dots$$

- 23.. What is the value of the product  $f(2) f^2(2) f^3(2) f^4(2) f^5(2)$ ?
- a.  $\frac{1}{3}$                       b. 3                      c.  $\frac{1}{18}$                       d. None of these
- 24..  $r$  is an integer  $\geq 2$ . Then what is the value of  $f^{r-1}(-r) + f^r(-r) + f^{r+1}(-r)$ ?
- a. -1                      b. 0                      c. 1                      d. None of these
- 25.. The area bounded by the three curves  $|x + y| = 1$ ,  $|x| = 1$ , and  $|y| = 1$ , is equal to
- a. 4                      b. 3                      c. 2                      d. 1
26. A shipping clerk has five boxes of different but unknown weights each weighing less than 100 kg. The clerk weights the boxes in pairs. The weights obtained are 110, 112, 113, 114, 115, 116, 117, 118, 120 and 121 kg. What is the weight of the heaviest box?
- a. 60 kg                      b. 62 kg                      c. 64 kg                      d. Cannot be determined
27. The set of all positive integers is the union of two disjoint subsets:  $\{f(1), f(2), \dots, f(n), \dots\}$  and  $\{g(1), g(2), \dots, g(n), \dots\}$ , where  $f(1) < f(2) < \dots < f(n) \dots$ , and  $g(1) < g(2) < \dots < g(n) \dots$ , and  $g(n) = f(f(n)) + 1$  for all  $n \geq 1$ .
- What is the value of  $g(1)$ ?
- a. 0                      b. 2                      c. 1                      d. Cannot be determined

28.. For all non-negative integers  $x$  and  $y$ ,  $f(x, y)$  is defined as below.

$$f(0, y) = y + 1$$

$$f(x + 1, 0) = f(x, 1)$$

$$f(x + 1, y + 1) = f(x, f(x + 1, y))$$

Then what is the value of  $f(1, 2)$ ?

- a. 2                                      b. 4                                      c. 3                                      d. Cannot be determined

### CAT 2001

29. Of 128 boxes of oranges, each box contains at least 120 and at most 144 oranges. The number of boxes containing the same number of oranges is at least

- a. 5                                      b. 103                                      c. 6                                      d. Cannot be determined

### CAT 2002

30. Ten straight lines, no two of which are parallel and no three of which pass through any common point, are drawn on a plane. The total number of regions (including finite and infinite regions) into which the plane would be divided by the lines is

- a. 56                                      b. 255                                      c. 1024                                      d. not unique

31.. Six persons are playing a card game. Suresh is facing Raghubir who is to the left of Ajay and to the right of Pramod. Ajay is to the left of Dhiraj. Yogendra is to the left of Pramod. If Dhiraj exchanges his seat with Yogendra and Pramod exchanges with Raghubir, who will be sitting to the left of Dhiraj?

- a. Yogendra                                      b. Raghubir                                      c. Suresh                                      d. Ajay

**Directions for questions 32 and 33:** Answer the questions based on the following information.

Each of the 11 letters A, H, I, M, O, T, U, V, W, X and Z appears same when looked at in a mirror. They are called symmetric letters. Other letters in the alphabet are asymmetric letters.

32.. How many four-letter computer passwords can be formed using only the symmetric letters (no repetition allowed)?

- a. 7,920                                      b. 330                                      c. 14,640                                      d. 4,19,430

33. How many three-letter computer passwords can be formed (no repetition allowed) with at least one symmetric letter?

- a. 990                                      b. 2,730                                      c. 12,870                                      d. 15,600

34. In how many ways is it possible to choose a white square and a black square on a chessboard so that the squares must not lie in the same row or column?

- a. 56                                      b. 896                                      c. 60                                      d. 768





**Directions for questions 41 to 43:** Answer the questions on the basis of the tables given below.

Two binary operations  $\oplus$  and  $*$  are defined over the set  $\{a, e, f, g, h\}$  as per the following tables:

$\oplus$	a	e	f	g	h
a	a	e	f	g	h
e	e	f	g	h	a
f	f	g	h	a	e
g	g	h	a	e	f
h	h	a	e	f	g

*	a	e	f	g	h
a	a	a	a	a	a
e	a	e	f	g	h
f	a	f	h	e	g
g	a	g	e	h	f
h	a	h	g	f	e

Thus, according to the first table  $f \oplus g = a$ , while according to the second table  $g * h = f$ , and so on. Also, let  $f^2 = f * f$ ,  $g^3 = g * g * g$ , and so on.

41. What is the smallest positive integer  $n$  such that  $g^n = e$ ?  
 a. 4                                      b. 5                                      c. 2                                      d. 3
42. Upon simplification,  $f \oplus [f * \{f \oplus (f * f)\}]$  equals  
 a. e                                      b. f                                      c. g                                      d. h
43. Upon simplification,  $\{a^{10} * (f^{10} \oplus g^9)\} \oplus e^8$  equals  
 a. e                                      b. f                                      c. g                                      d. h
44. A survey on a sample of 25 new cars being sold at a local auto dealer was conducted to see which of the three popular options — air conditioning, radio and power windows were already installed.

Following were the observation of the survey:

- I. 15 had air conditioning
- II. 2 had air conditioning and power windows but no radios
- III. 12 had radio
- IV. 6 had air conditioning and radio but no power windows
- V. 11 had power windows
- VI. 4 had radio and power windows
- VII. 3 had all three options

What is the number of cars that had none of the options?

- a. 4                                      b. 3                                      c. 1                                      d. 2

### CAT 2004

45.  $N$  persons stand on the circumference of a circle at distinct points. Each possible pair of persons, not standing next to each other, sings a two-minute song one pair after the other. If the total time taken for singing is 28 minutes, what is  $N$ ?  
 a. 5                                      b. 7                                      c. 9                                      d. None of the above

**Directions for questions 46 and 47:** Answer the questions on the basis of the information given below.

$$f_1(x) = x \quad 0 \leq x \leq 1$$
$$= 1 \quad x \geq 1$$
$$= 0 \quad \text{Otherwise}$$

$$f_2(x) = f_1(-x) \text{ for all } x$$

$$f_3(x) = -f_2(x) \text{ for all } x$$

$$f_3(x) = f_3(-x) \text{ for all } x$$

46. How many of the following products are necessarily zero for every  $x$ .

$$f_1(x)f_2(x), f_2(x)f_3(x), f_2(x)f_4(x) ?$$

- a. 0                                      b. 1                                      c. 2                                      d. 3

47. Which of the following is necessarily true?

- a.  $f_4(x) = f_1(x)$  for all  $x$                                       b.  $f_1(x) = -f_3(-x)$  for all  $x$   
c.  $f_2(-x) = f_4(x)$  for all  $x$                                       d.  $f_1(x) = f_3(x) = 0$  for all  $x$

### CAT 2005

48. In a chess competition involving some boys and girls of a school, every student had to play exactly one game with every other student. It was found that in 45 games both the players were girls, and in 190 games both were boys. The number of games in which one player was a boy and the other was a girl is

- a. 200                                      b. 216                                      c. 235                                      d. 256

49. For which value of  $k$  does the following pair of equations yield a unique solution of  $x$  such that the solution is positive?

$$x^2 - y^2 = 0$$

$$(x - k)^2 + y^2 = 1$$

- a. 2                                      b. 0                                      c.  $\sqrt{2}$                                       d.  $-\sqrt{2}$

50. Consider a triangle drawn on the X-Y plane with its three vertices of (41, 0), (0, 41) and (0, 0), each vertex being represented by its (X, Y) coordinates. The number of points with integer coordinates inside the triangle (excluding all the points on the boundary) is

- a. 780                                      b. 800                                      c. 820                                      d. 741

51. In the X-Y plane, the area of the region bounded by the graph  $|x + y| + |x - y| = 4$  is

- a. 8                                      b. 12                                      c. 16                                      d. 20

52. Let  $g(x)$  be a function such that  $g(x+1) + g(x-1) = g(x)$  for every real  $x$ . Then for what value of  $p$  is the relation  $g(x+p) = g(x)$  necessarily true for every real  $x$ ?

- a. 5                                      b. 3                                      c. 2                                      d. 6